

Smart Elevator Tech, LLC

Deflector Sheave Isolators™

Fully engineered, bolt in place isolation assemblies for elevator deflector sheaves.

The vibration and harmonics produced by even the finest elevator traction machine can be transmitted through the hoist ropes to the deflector sheave. If the deflector sheave is not isolated from the building structure, the machine vibration can be transmitted through the deflector sheave to the machine beams, the perimeter building steel and floor decks and walls of adjacent living space.

The result is amplification of these vibrations, a phenomenon called resonance. The natural frequency of the structure is aggravated by the machine frequency with a compounding effect. The floor decks begin to resonate, much like the skin of a drum. This is often called structural noise as it emanates from the building structure.

A common approach is to add insulation, sound proofing materials or sound barriers. These "solutions" typically fail as the noise is actually emanating from the structure, including the living space floors and walls, which are acting as amplifiers for the vibration source.

The correct solution is to properly isolate the original source of the vibration. Typically elevator drive machines are isolated at their mounting, most commonly with neoprene pads or engineered isolators. Most deflector/secondary sheaves, however, are bolted directly to the underside of the machine beams and are not isolated from the building structure.

Now there is a practical solution for isolating deflector/secondary sheaves, the **Deflector Sheave Isolators™** from **Smart Elevator Tech, LLC**. Each order is specifically engineered for the project based on the system weights (load), the degree of deflection (radian), the center of sheave to pillow block dimensions (offset), car v. cwt. deflecting (static or variable), etc.

Complex vector mechanics mathematics is utilized to determine the tangential loading and the orthogonal vertical and horizontal forces independently for the isolator assembly at each side of the sheave. The calculations then compare the specific vertical and horizontal loading for each mount with an array of engineered isolators designed for the low frequencies (Hz) of elevator machine and selects the ideal combination in each direction and for each side of the sheave.

For ease of installation, the **Deflector Sheave Isolators™** are designed to bolt to the machine beams using the same holes as the original deflector sheave. This allows the isolators to be installed with the elevator installation or added as a retrofit without having to drill new holes in the machine beams. The assemblies typically require 6.75" of vertical space, lowering the deflector sheave by that amount. Care must be taken to center the deflector sheave with the plumb rope drop so as to eliminate any side pull on the sheave or isolators.

The isolator assemblies are manufactured with pride in the USA to strict tolerances. Each isolator assembly is labeled for the specific sheave side and the set carries a unique serial number. Drawings are provided identifying the isolators used, should replacement ever prove necessary. The design has been certified by a California licensed structural engineer. Job specific structural certification is available if required (fees apply).

As every set of isolators must be custom built to the elevator loading parameters, lead time is approximately three weeks from order placement and completed survey forms. Feel free to give us a call to discuss your project and for actual pricing and lead time.

Call (415) 819-5744

or email

rich@smartelevatortech.com

for pricing

www.smartelevatortech.com/DSI.htm

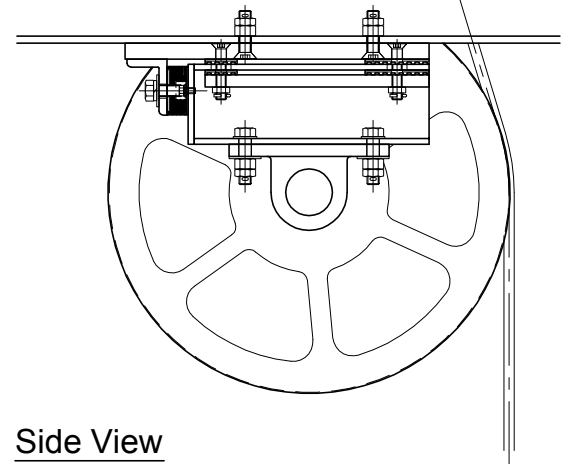
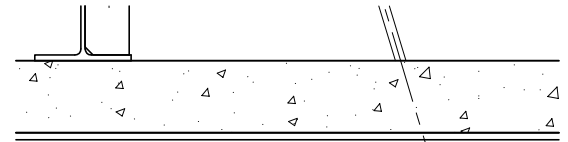

Side View

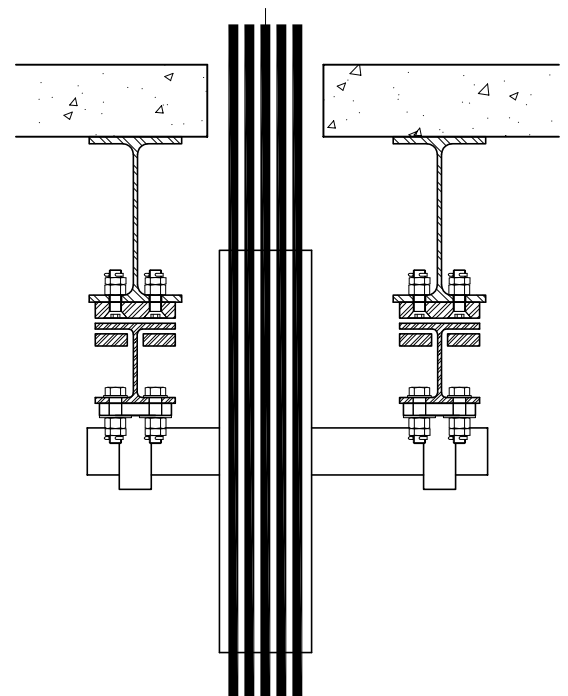

Front View