

Note: For divider beam installation, use "Divider Beam Kit" (#DBK) and see separate drawing: Retracta Ladder® Installation w/ Divider Beam Kit (#DBK). Bottom brackets must be lowered to 1 3/4" above base of ladder and different R.H. bottom bracket is required.

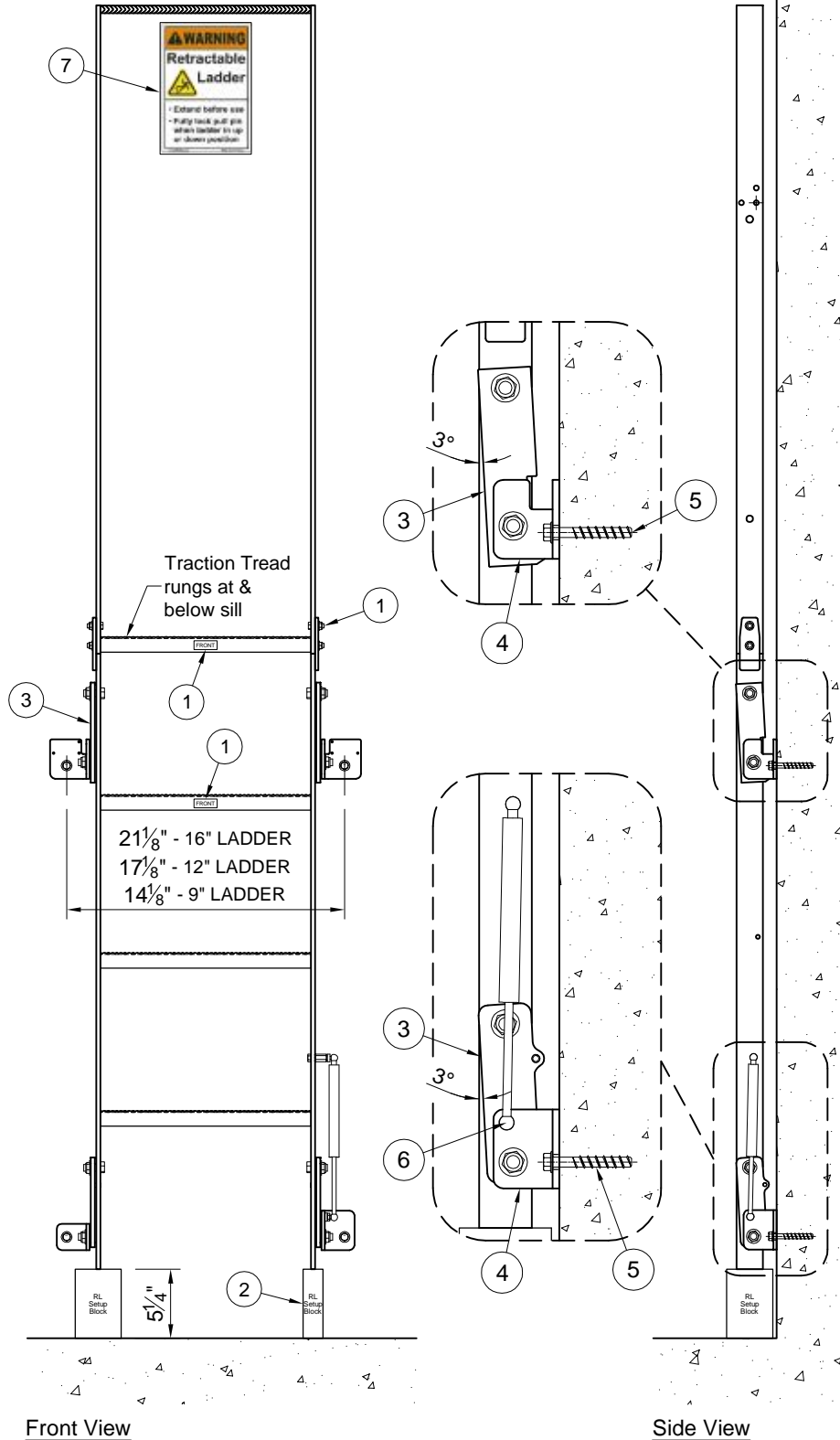

Retracta Ladder® Installation Steps

- 1 Assemble ladder sections using 5/16"-18 fasteners provided. Assure straight alignment of all sections with "FRONT" stickers toward elevator.
 - 2 Set ladder in position against mounting surface. Set ladder bases onto provided 5 1/4" high Setup Blocks, one parallel to wall and one perpendicular to wall for greater stability.
 - 3 Point each pivot arm downward offset 3° from vertical.
 - 4 Rotate each wall bracket to align angle leg with mounting surface. Verify all points of attachment are plumb - shim if required.
 - 5 Anchor brackets to wall with 3/8" concrete screws, wedge anchors or other appropriate fasteners (not incl.). Add shims if required to provide a straight, plumb plane (shims not incl.).
 - 6 Connect gas strut piston cup to ball connector, replace wire clip. Note, piston must be pointed downward.
 - 7 Mount "Warning - Retractable Ladder" sign to wall, visible from entrance with ladder in retracted position. Provide mounting surface if required.
- continued on page 2 --

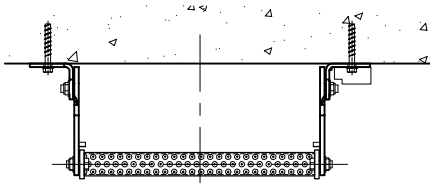

Section 'A-A'

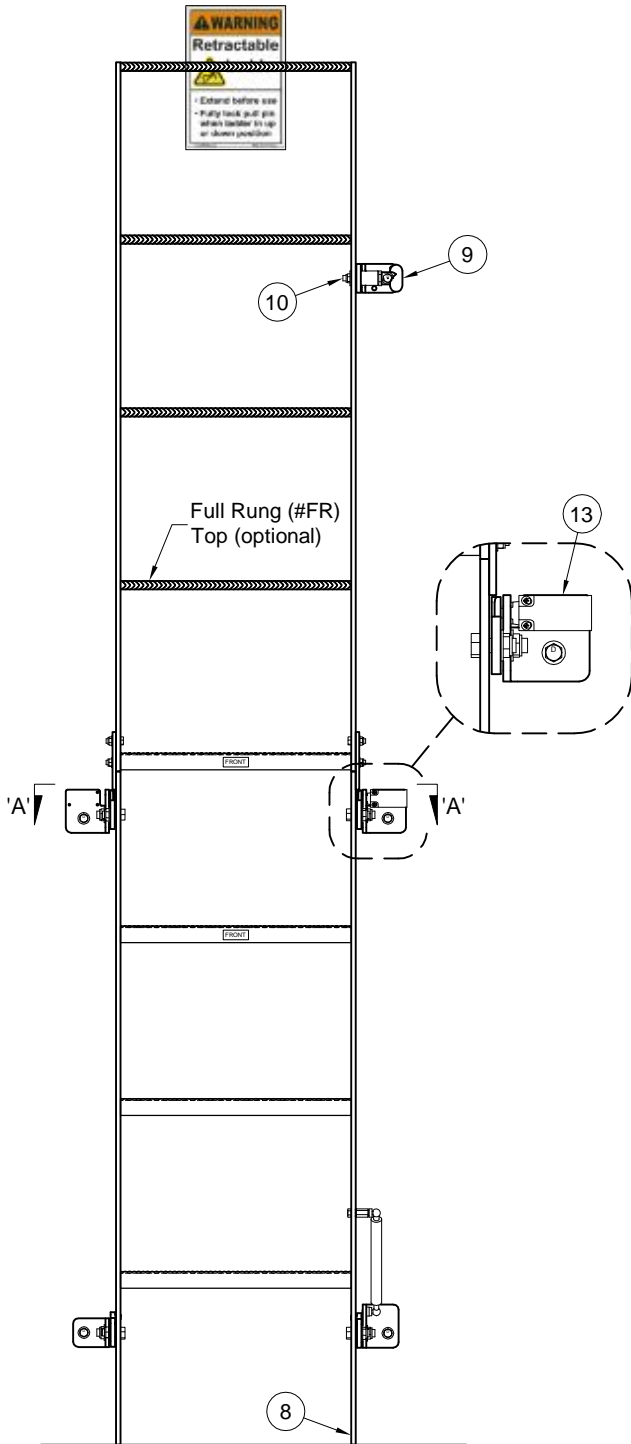

Front View

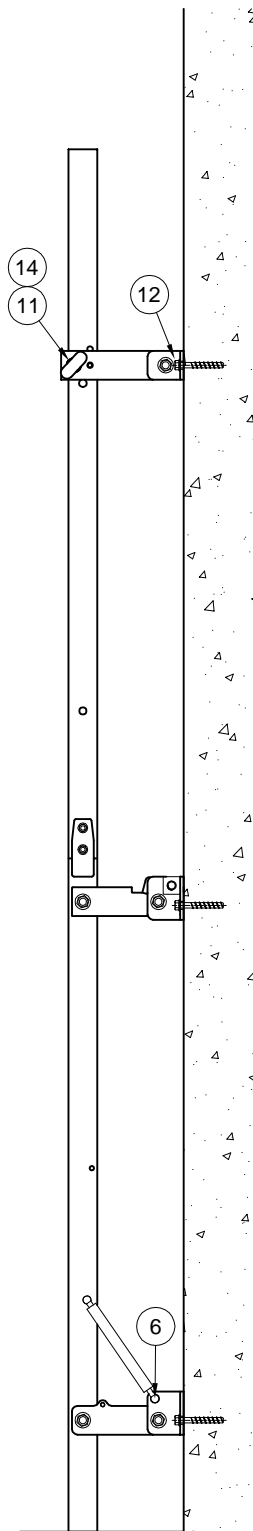

Side View

-- continued from page 1 --

- 8 Remove Setup Blocks so that ladder bases rest onto the pit floor.
- 9 Verify hand (RH shown) of top Pull-Pin Bracket Assy. Must be on side closest to entrance. Reverse if required.
- 10 Attach Pull-Pin bracket assy. to ladder riser into bottom inside hole of 3-hole pattern with $\frac{3}{8}$ -16 thin nylon insert nut. Provide additional grease if dry. Do not tighten - leave sufficiently loose for proper pivot arm movement.
- 11 Fasten this connection to structure with Pull-Pin locked in lower outside hole of 3-hole pattern. Move bracket up & mark, then down & mark and then fasten to Unistrut at middle between marks.
- 12 Anchor Pull-Pin bracket assy. to wall or support, with shims if required (not included). For drywall applications, add structural blocking in wall or surface mount Unistrut columns to pit floor - maximum 200 lbs vertical load.
- 13 Mount roller-plunger switch to middle height bracket on either side of ladder, as suited for wiring to pit stop switch or to elevator controller. Use provided 8-32 screws & washers. Pipe & wire N.C. switch contacts in series with pit switch or dedicated run to controller, if provided.
- 14 Test operation of ladder and switch. Verify opening of the elevator safety circuit (removal of power from motor & brake) with ladder in the extended position. Switch & safety circuit remain open until ladder is retracted upon exiting pit. Ensure ladder fully locks via Pull-Pin in both retracted and extended positions.